



## AD-444 Specifications

Tumbler Capacity (dry weight)	45 lbs. (20.41 kg) x 2	
Tumbler Diameter	32-3/4" (83.19 cm)	
Tumbler Depth	30" (76.20 cm)	
Tumbler Volume	14.6 cu ft (413.43 L)	
Tumbler/Drive Motor	3/4 hp (0.56 kW)	
Blower/Fan Motor	N/A	
Door Opening (Diameter)	27" (68.58 cm)	
Door Sill Height	top pocket	50-1/4" (127.64 cm)
	bottom pocket	10-1/4" (26.04 cm)
Dryers per 20'/40' Container	8 / 16	
Dryers per 48'/53' Truck	25 / 27	
Width	34-5/16" (87.15 cm)	
Depth	53-3/16" (135.02 cm)	
Height	80-15/16" (205.6 cm)	
Airflow	60 Hz	530 cfm (15 cmm)
	50 Hz	442 cfm (12.52 cmm)
Exhaust Connection	8" (20.32 cm) Standard x2 10" (25.4 cm) Optional x1	
GAS MODEL:	Voltage Available	120-240v 1ø, 2w
	Approx. Net Wt.	905 lbs (410.5 kg)
	Approx. Ship Wt.	940 lbs (426.4 kg)
	Heat Input (per pocket)	106,000 btu/hr (26,712 kcal/hr)
	Inlet Pipe Connection (per pocket)	1/2" F.N.P.T.

Specifications in parentheses are metric equivalents.

9/10/15

Electrical Specs listed are per pocket.

### Electrical Service Specifications

GAS					
SERVICE VOLTAGE	PHASE	WIRE SERVICE	APPROX AMP DRAW		CIRCUIT BREAKER
			60 Hz	50 Hz	
120	1ø	2	12.0	--	15
208	1ø	2	7.0	--	15
220	1ø	2	6.8	--	15
240	1ø	2	6.5	--	15

OPTIONAL 10" EXHAUST CONNECTION FRONT VIEW

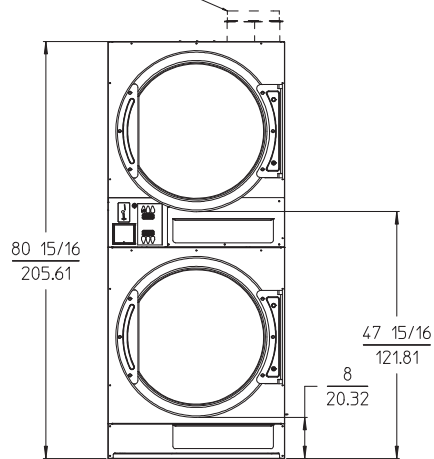

REAR VIEW

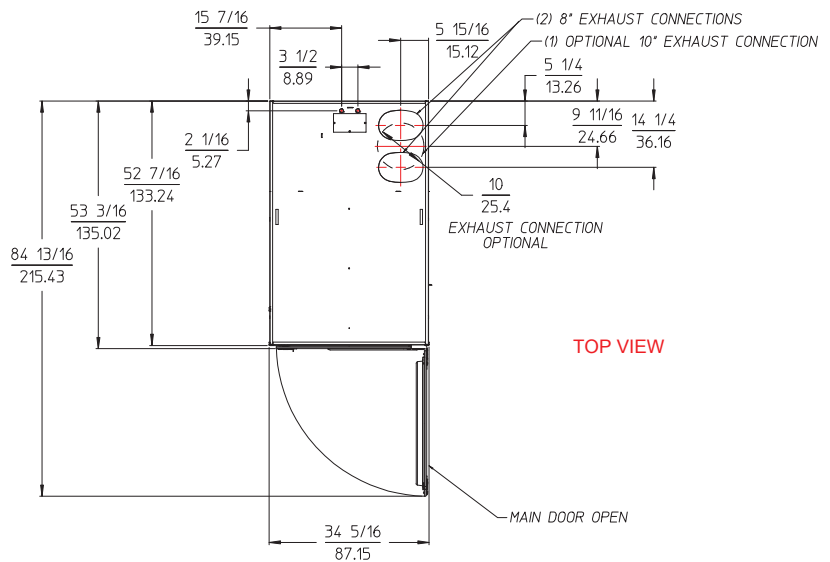
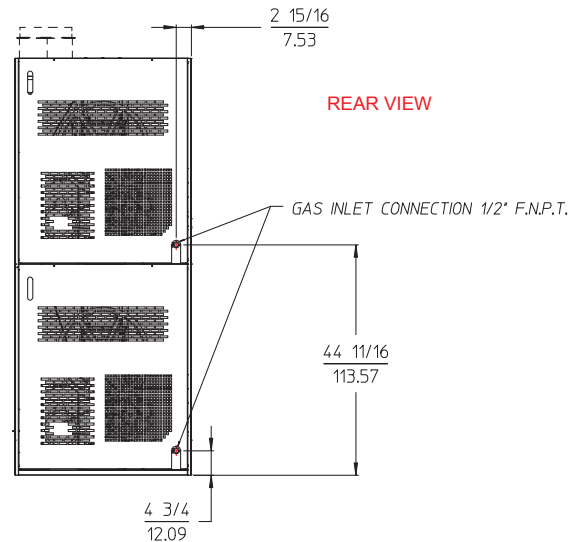

451061 Rev. 10/16

88 Currant Road Fall River, MA 02720-4781 • 508.678.9000